

Airpura

AIR PURIFIERS

R600

All Purpose

Remove Dangerous Airborne Chemicals and Particles From Your Indoor Air

The EPA has stated that indoor air quality is now the number one environmental health concern.

The R600's powerful 560 CFM impeller draws air through an 18lb Carbon Bed and True HEPA filter to clean your indoor air and help protect you and your family from the health hazards of living in polluted indoor air.



Poor quality indoor air may contain

Particles

Pet dander	Pollen	Mold spores
Dust mites	Droplets	Asbestos
		Tobacco Smoke

Airborne Chemicals

Formaldehyde	Radon	Methylene Chloride
Ammonia	Glues	Mold Mycotoxins
Benzene	Pesticides	Perchloroethylene

Symptoms associated with poor quality indoor air

Allergies	Runny noses	Damage to liver,
Asthma	Eye irritations	kidney and central
Dry throats	Nausea	nervous system
Wheezing	Loss of coordination	
Coughing	Cancers	

The Airpura R600

Available in
White / Black / Cream

The Airpura Limited Warranty
5 years parts 10 years labor

Long Lasting Filters

Carbon filters typically last up to 2 years depending on use

Hepa filters typically last 5 years in regular use.

Pre-filters can be vacuumed from the exterior of the unit and should be changed every 12 months depending on use

Feel the Difference Breathing Clean Air Makes to Your Health

Airpura AIR PURIFIERS

R600

All Purpose Unit

Technical Specifications

Odors, airborne chemical control

18 lbs activated carbon
13" x 13" x 9"

Carbon bed

2" deep x 570 sq" surface

Particle removal

40 sq ft true HEPA
(Measured 1 side only)
10 pleats per inch
Pleats warm rolled with separators

Air Flow 560 cfm

More cfm than any other home unit available

Pre-filter

570 sq in x 1 in

Housing

Powder coat steel

Size

23" x 15"

Weight

45lbs total

Voltage Options

115 or 220 volts

Watts

120 on high 40 on low

Sound Level

28.1 db on low (at 6 feet)
62.3 db on high (560 cfm)
(Room Level 25.1)

ETL Certified

Conforms to
CSA C22.2 no 113
ANSI / UL 507

Your Airpura Dealer

Unique Features

- Pressure seal Airpura's unique pressure seal on the filter chamber ensures that all of the dirty air passes through the filters. Other systems allow leakage and do not achieve the 99.97% HEPA filtration rating
- Felt gaskets seal the filter chamber. Maximize filtration with no rubber off-gassing found with other filters
- All metal housing ensures no plastic vapors are emitted
- Backward curved motorized impeller eliminates the vibrations and noise associated with older motor and shaft set ups
- Variable speed motor lets you choose your ideal level of filtration
- Motor out of the air flow. Most air purifiers blow the clean air over the motor and pick up fresh impurities
- Unimpeded airflow simple and direct internal airflow avoids the air turbulence, inefficiency and noise associated with more convoluted systems
- Separate electrical parts chamber prevents any off gassing from capacitors, condensers or switches.
- Perforated steel exterior offers both a softer appearance and 360 degree air intake and distribution.
- Separately changeable filters The Hepa and carbon filters can be changed separately so you only change them when appropriate and save operating costs

High Efficiency Filtration

Cleanable pre-filter

Vacuum through grill and change every 12 months

18 lbs 2" Carbon bed

Absorbs airborne chemicals noxious gases and odors

HEPA filter

Traps 99.97% of particles as small as 0.3 microns

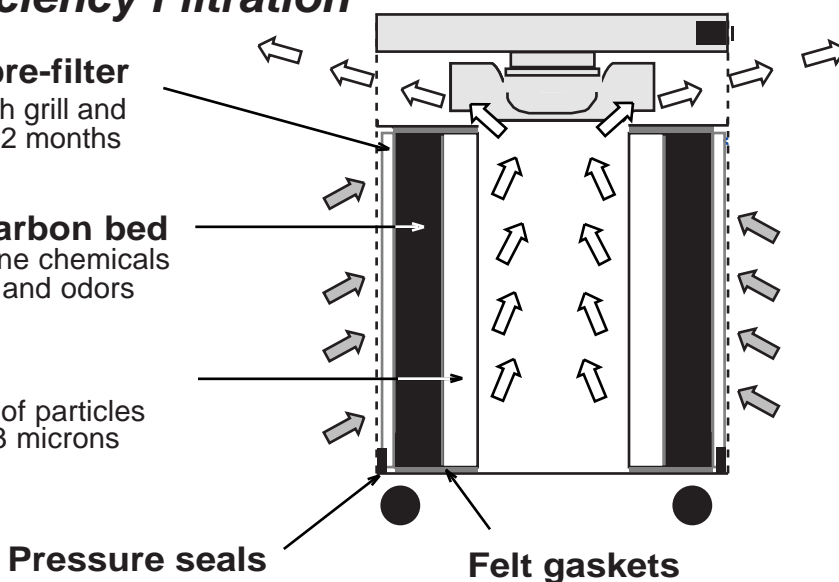

True HEPA Filters

Developed by the atomic energy commission to filter radio active particles as small as 0.3 microns

Activated Carbon

Used in water filtration and in military gas masks, it can adsorb 60 % of it's own weight of airborne chemicals

Safe effective air purification for home, office and workplace