

Airpura

AIR PURIFIERS

C600-DLX

Specific Chemicals - VOCs

***Remove Specific Airborne Chemicals
including Volatile Organic Compounds***

**The Airpura C600 DLX
Enhanced Chemical Abatement Unit
offers you:**

■ **26 lb enhanced impregnated activated carbon bed**

Adsorbs airborne chemicals including volatile organic compounds (VOCs)

■ **HEPA-barrier post filter**

Traps particles after the carbon bed

■ **560 CFM integrated fan / motor**

Largest CFM available in a portable unit

■ **Variable speed control**

Gives you flexible air flow options

■ **Proper contact times for effective filtration**

Correctly calibrated air flow / bed depth for efficient adsorption.

■ **Pressure sealed filter chamber**

Unique pressure seal on the filter chamber ensures all contaminants are filtered and non escape

■ **The Airpura Limited Warranty**

5 years parts 10 years labor

■ **Call our air quality experts**

For the solution to your air pollution problem

■ **Over 4000 chemicals can be removed**

Carbon blends are available to deal with over 4000 airborne chemicals including:

Ammonias
Nitrous dioxide
Nitrous trioxide
Monoethylamine

Hydrogen Sulfide
Mercury vapors
Chlorine dioxide
Hydrogen Bromide
Sulfur dioxide

Hydrogen fluoride
Hydrogen chloride
Benzene
Methylene Chloride
Radioactive Iodine

Toulene
Naphthene
Pesticides
Chlorine
Mold Mycotoxins



The Airpura C600 DLX

Available in
White / Black / Cream

Filter Life

Carbon filters should be changed as needed in heavy applications and at least every 24 months in normal use. Airpura carbon canisters are refillable to save costs
HEPA Barrier filters should be changed every 12 months

Pre-filters can be vacuumed from the exterior of the unit and should be changed every 12 months depending on use

Protect Yourself with Airpura High Efficiency Air Purification

Airpura

AIR PURIFIERS

C600-DLX

Airborne Chemicals & VOCs

Technical Specifications

Odor, airborne chemical and VOC control

26 lbs super enhanced impregnated activated carbon 13" x 13" x 7.5"

Carbon bed

3" deep x 570 sq" surface

Air Flow 560 cfm

More cfm than any other portable unit available

Pre-filter

570 sq in x 1in

Post particle filter

306 sq in

Size

Weight

49lbs total

Voltage Options

115 or 220 volts

Watts

120 on high
40 on low

Sound Level

28.1 db on low (at 6 feet)
62.3 db on high (560 cfm)
(Room level 25.1 db)

ETL Certified

Conforms to
CSA C22.2 no 113
ANSI / UL 507

Your Airpura Dealer

Filtration system

Cleanable pre-filter
Vacuum through grill and change every 12 months

26 lb Enhanced Impregnated Carbon filter
Enhanced carbon to capture VOCs more efficiently

HEPA-Barrier post filter
Traps carbon dust and particles

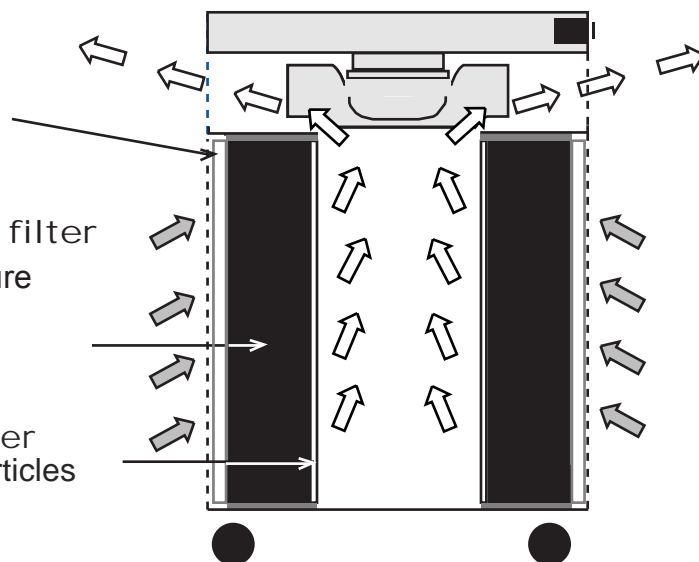

Unique Features

- **All metal housing** ensures no plastic vapors are emitted.
- **Motor out of the air flow.** Most air purifiers blow the clean air over the motor and pick up impurities.
- **Electrical parts in a sealed chamber** out of the airflow. Increases safety and prevents off-gassing.
- **Pressure sealed filter chamber** prevents leakage of polluted air around filters.
- **Felt gaskets seal the filter chamber.** Maximize filtration with no rubber off-gassing found with other filters.
- **Clean modern appearance**
- **Low noise level**

Specially designed to remove specific airborne chemicals and VOCs

Dwell time

For best results the correct dwell time of the pollutants over the enhanced impregnated carbon bed is vital. The 560 CFM impeller/motor combined with the variable speed control and unimpeded airflow of the Airpura 600 series allows you to set the airflow precisely and achieve the results you need.

Expertise you can call on

Airpura air quality experts can offer you a solution to most airborne chemical problems. Contact your Airpura dealer or call us directly to discuss your needs.

Safe effective air filtration for your better health