

# BA-1000 Ion Distribution System

Ionization Product Specifications

Revision: D 2/9/21

## Product Summary

The BA-1000 Ion Distribution System is changing the game in Air Purification Technology. These systems offer a 24/7, proactive approach. The BA-1000 ionizer is UL-2998 certified for zero ozone emissions and UL-867 certified.

These units are designed for room installation to proactively attack airborne pathogens directly at the breathing zones. BSE's Ion Distribution System works independently or in conjunction with the HVAC system.

BSE units are manufactured in to feature a "Plug and Play" industrial grade construction. The advanced aeroacoustic discharge ports coupled with our proprietary ionization technology, optimize the ion plume discharge, and elongates the ion's life span to correspond geometrically to the room's breathing zones. The result is a continuous discharge of millions of ions saturating the room breathing zones and mitigating the airborne pathogens.

**Includes 6-speed Bluetooth Wireless remote!**

## Benefits



**Pathogens Killed (Bacteria, Viruses, Mold), Helps to Control Allergens/ Asthma, Prevent Sick Building Syndrome**



**Particle Reduction and Smoke Control**



**Odors Neutralized by destroying VOCs**



**Energy Savings of 30% by Reducing Outdoor Air Intake by up to 75%.**

## Standard Features

Stand-alone, wall mounted air purifying unit delivering a 24/7, proactive approach to indoor air quality.

The unit covers up to 2650 square feet.

Virtually zero maintenance is required!

## Commercial Applications

- ✓ Schools and Universities
- ✓ Healthcare
- ✓ Gyms & Athletics
- ✓ Restaurants
- ✓ Hospitality
- ✓ Salons
- ✓ Senior Living Facilities
- ✓ Office Buildings
- ✓ New Construction
- ✓ Co-working Spaces
- ✓ Transportation Facilities



## Important Information

Competitor's ion output ratings generated directly at the needlepoint brushes can be deceiving as is shown by our testing and published numbers. Ionization units not installed directly in the breathing zones are not conducive for maximizing ion output at all the breathing zones. See the Total Ion Output table for ion output directly to the breathing zones. Please evaluate the HVAC air distribution system (duct, insulation, vav terminals, dampers turning vanes) and account for the coanda effect of air distribution diffusers. These variables could result in little to no ions being discharged to the breathing zones. BSE's Ion Distribution products are rated and tested for ion output from 2 feet to 25 feet away from the needlepoint brushes at the breathing zones for real world performance. Please make sure when specifying Bipolar Ionization that the ion's per cc/sec are commensurate to the distance required at the breathing zones to mitigate airborne viruses.

Fan Output	5 ft	10 ft	15 ft	20 ft	25 ft
Level 1	870,000	310,000	185,000	100,000	70,000
Level 2	1.1 Million	330,000	275,000	140,000	100,000
Level 3	1.2 Million	355,000	325,000	165,000	120,000
Level 4	1.4 Million	400,000	375,000	180,000	150,000
Level 5	1.4 Million	460,000	450,000	200,000	170,000
Level 6	1.5 Million	575,000	500,000	225,000	150,000



BSE, Inc.

[www.bsesales.com](http://www.bsesales.com)

T: (866) 360-5675

[Sales@bsesales.com](mailto:Sales@bsesales.com)

# BA-1000 Ion Distribution System

Ionization Product Specifications

Revision: C 1/21/2021

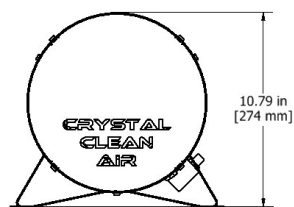
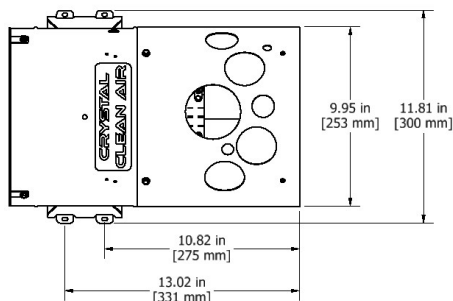
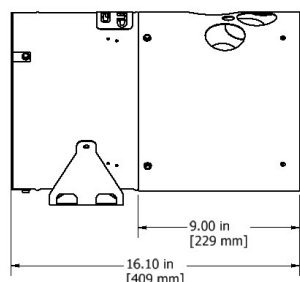

## Specifications

Optional Portable Feature (Sold Separately)

Model	BA-1000
Unit Dimensions	10" Diameter (254) /Length 16.10(409) inches (mm)
Material Casing	Steel
Plug Length	6.5 Feet
Fan	6-pole Brushless EC with Auto-Restart Lock Protection and Soft Start
Airflow Capacity	1065 CFM
Static Pressure	2.09 in H <sub>2</sub> O (520 Pa)
Max Speed	3,200 RPM
Sound Output*	45-65 dB
Speed Controller	PWM, 0-10V, 6 Speed Wireless Remote
Fan Bearings	Dual Ball NMB
L10 Life Expectancy	70,000 Hours
Weight	13.6 lbs.
Maximum Operating Temperature	15°F – 140°F
Electrical: Voltage Input	110-120V AC
Power Consumption	150-Watt
Frequency	50/60 Hz
Current	1.84A
Certifications	UL 2998, UL 867 ETL Listed, fan conforms to UL Standard 507, Fan Blade UL 94 V-0

\* Sound Output was measured at 5 feet from the unit.



BSE, Inc.  
www.bsesales.com  
T: (866) 360-5675  
Sales@bsesales.com