



OWNER'S MANUAL

A-2500 Series

Installation and Service Manual

**INTRODUCTION
SPECIFICATIONS
UNPACKING
MOUNTING
ELECTRICAL
OPERATION
MAINTENANCE
REPLACEMENT PARTS
TROUBLESHOOTING**

*****IMPORTANT*****

THIS MANUAL CONTAINS PRECAUTIONARY STATEMENTS RELATING TO WORKER SAFETY. READ AND SAVE THIS MANUAL COMPLETELY AND COMPLY AS DIRECTED. ALL THE POTENTIAL HAZARDS OF DUST AND MIST CONTROL SYSTEMS AND EQUIPMENT ARE IMPOSSIBLE TO LIST; THEREFORE, OBTAIN THE SERVICES OF A PROFESSIONAL INSTALLER. A FIRE PROTECTION EXPERT SHOULD BE OBTAINED IN THE EVENT THE PRODUCT IS INTENDED FOR USE THAT PRESENTS A POTENTIAL RISK OF FIRE OR FIRE PROPAGATION. REFER TO APPROPRIATE AUTHORITIES AND DISCUSS YOUR INTENDED USE WITH BSE. WORKERS HANDLING EQUIPMENT OR SYSTEMS SHOULD BE INSTRUCTED TO CONDUCT THEMSELVES IN A SAFE MANNER.

RETAIN THESE INSTRUCTIONS FOR FUTURE REFERENCE.

**BSE Contact Info:
W. www.purexinc.com
T. 866.360.5675
E. sales@purexinc.com**

SPECIFICATIONS FOR THE BSE A-2500

Cabinet	16 GA Cold Rolled Steel
Finish	BSE Blue Polyurethane Chemical Resistant Powder Coat Paint
Size	Dimensions: 24" x 24" x 59"
Weight	160 lbs
Noise Level	65 dBA at 5'
Power	115 Volt 10.2 AMPS 950 Watts
Capacity	2500 to 3000 cfm
Motor	¾ hp Permanent Split Capacitor (PSC) with thermal overload
Switch	On/Off switch, with low and high settings. 10' cord w/ single phase unit
Blower	10 by 10 Direct Drive Centrifugal Forward Curve
Grille	Four-way individually adjustable blades
Filter Size	Standard Unit: (1) 35% Pre-Filter and (1) 95% Primary Bag Filter (24" x 24" x 36") HEPA Unit: (1) 35% Pre-Filter, (1) 95% Bag Filter (24" x 24" x 15"), and (1) HEPA Filter
Options	Wrap-A-Round Pre-filter Cage Washable Aluminum Pre-filter HEPA Filter Carbon Filter Silencer with Louver (reduces noise from fan exhaust by 8 decibels) Magnehelic Pressure Gage (shows when to change filters) 208-230 Single Phase Motor (5.6 AMPS) Needlepoint Bipolar Ionization unit
Mounting Options	Ceiling Kit: (4) Eyebolts Pre-Installed with Chain Hanging Kit OR Wall Mount Kit: (2) L Shaped Wall Brackets
Warranty	Three year on all parts, does not include filters

SAFETY RULES

Follow all electrical and safety codes as well as the National Electrical Code (NEC), National Fire Protection Association (NFPA), and the Occupational Safety and Health Act (OSHA). Qualified personnel should perform all electrical connections and wiring only.

National Fire Protection Association (NFPA) standards require specific duct design and dust collector configuration when collecting potentially reactive metal dusts, such as aluminum, magnesium, and other materials. NFPA also covers other dusts such as grain and plastics, etc. A guideline for determining the precautions to be taken can be found in NFPA 497. Other NFPA standards may apply to your specific application. Consult current NFPA standards, available for NFPA, 1 Batterymarch Park, Quincy, MA, 02269, 800-344-3555, for applicable safeguards which may be required for the Installation, Operation, and Service of this product.

Additional references are the Uniform Building Code and the Uniform Mechanical Code.

WARNING

1. Avoid mixing combustible materials such as (but not limited to) buffing lint, paper / wood dust, aluminum or magnesium with dust generated from the grinding of ferrous materials. This creates a potential for fire due to the mixing of sparks and combustible materials.
2. Under no conditions should the machine operator be allowed to put lit cigarettes or any burning object into this or any dust/mist control system.
3. Installation of this unit in applications where there is a chance for heated and/or flammable materials to enter the unit should be evaluated to determine if a fire protection/extinguishing system should be installed. Federal, state or local codes, a required by organizations such as NFPA and Factory Mutual Insurance or your insurance carrier may require such a system. BSE can offer basic guidelines for such an installation; however, final installation design is the responsibility of the filtration unit Owner/User.
4. Explosion relief vents are required on some applications. Consult with an insurance underwriter or an NFPA manual to determine proper vent size ratio. Dust or mist collectors must be located outdoors unless otherwise indicated by NFPA standards. Dust and mist collectors DO NOT CONTAIN EXPLOSION RELIEF VENTS as shipped from the factory and must be field installed per NFPA standards.

Always use BSE replacement filters - for reordering, please contact us at 866-360-5675

BSE LIMITED WARRANTY

BSE warrants all products sold, only to purchasers for use in business or for resale, against defects in workmanship or materials under normal use for 3 years after date of purchase from BSE. This warranty does include standard warranties from purchased parts such as blowers, motors, valves, etc. All purchased items will fall under the manufacturers' standard warranty. Any part which is determined to be defective in material or workmanship and returned to BSE or authorized service facility, as BSE designates, shipping cost prepaid, will be, as the exclusive remedy, repaired or replaced, at BSE option. Any liability for consequential and incidental damage is expressly disclaimed. BSE liability, in all events, is limited to and shall not exceed, the purchase price paid.

Title and risk of loss pass to buyer on delivery to the common carrier. If product is damaged in transit, recipient must file claim with carrier. BSE will make a good faith effort for prompt correction or other adjustments with respect to any product that proves to be defective within the warranty period.

DISCLAIMER

Although instructions and recommendations are included for installation or your mist or dust collector equipment, the manufacturer does not assume responsibility for the installation of this equipment nor shall be held liable for direct or consequential damages resulting from improper methods, structural failure or inadequate supports.

BSE Contact Info:
W. www.purexinc.com
T. 866.360.5675
E. sales@purexinc.com

SAFETY

READ AND SAVE THIS MANUAL COMPLETELY AND COMPLY AS DIRECTED. THIS MANUAL CONTAINS PRECAUTIONARY STATEMENTS RELATING TO WORKER SAFETY. WORKERS HANDLING EQUIPMENT OR SYSTEMS SHOULD BE INSTRUCTED TO CONDUCT THEMSELVES IN A SAFE MANNER. ALL THE POTENTIAL HAZARD OF DUST AND MIST CONTROL SYSTEMS AND EQUIPMENT ARE IMPOSSIBLE TO LIST. THEREFORE, OBTAIN THE SERVICES OF A PROFESSIONAL INSTALLER. A FIRE PROTECTION EXPERT SHOULD BE OBTAINED IN THE EVENT THE PRODUCT IS INTENDED FOR USES, WHICH PRESENT A POTENTIAL RISK OF FIRE OR FIRE PROPAGATION. REFER TO APPROPRIATE AUTHORITIES AND DISCUSS YOUR INTENDED USE WITH YOUR BSE REP.

Initial Inspection

If your new BSE units were shipped in by truck you should inspect the carton for damages or possible shortages. If there are any signs of possible shipping damages, unpack the units and make a note of the shortage or damage on the freight bill before signing it. If the carton is opened at a later time and there is damage to the unit, you should file a concealed damage claim with the delivery carrier. They are responsible for any damages in shipment or shortages that were actually shipped.

Installing Your Unit

All installations must meet all electrical or mechanical building codes that may apply in your particular area. If there are no local requirements, you should follow the National requirements.

All chains, hooks, bolts and other items used in installation must be at least strong enough to support FOUR times the weight on each unit. Check with your rep to verify weight of unit you have purchased.

Methods for Mounting your BSE A-2500 unit

There are many different ways to install your units. The most common method of installing the units is to support them from the ceiling structure with four chains. If you are going to use this method, you should drill 4 holes down through the top of the unit approximately 8" in from each end and 3/4" in from each side of the unit. Use at least 5/16" eyebolts with nuts and washers both inside and outside of the unit. The top end of the chains must be secured to the ceiling structure in a safe and acceptable manner. Be sure your unit is connected to the proper voltage and is protected by correct size fuses or breakers.

BSE products are designed to improve your environment. A-2500 series collects dust, smoke, oil mist, oil smoke, and other atmospheric pollutants in industrial plants, shops, schools, and factories with high efficiency, 2 or 3 stage filtrations. It is a complete air filter packaged unit that can be installed easily and used as a free hanging air filter unit to clean the ambient pollutants, smoke and haze.

The BSE A-2500's consists of a 4" pleated prefilter that traps dust and larger particles. The second stage, micro-glass multi-pocket bag filter has 98% resistance and either 65 or 95% efficiency (depending on the application) on the atmospheric dust spot test, removing smoke and other submicron size particles from the air. Changing out the filters is easy as it requires no tools. The 4" prefilter pulls from the unit and can be replaced. The main filter is located directly behind the 4" prefilter and pulls out also. For light odors, there is an optional 2" 50% bypass charcoal filter available.

Option 1 - Ceiling mounting methods

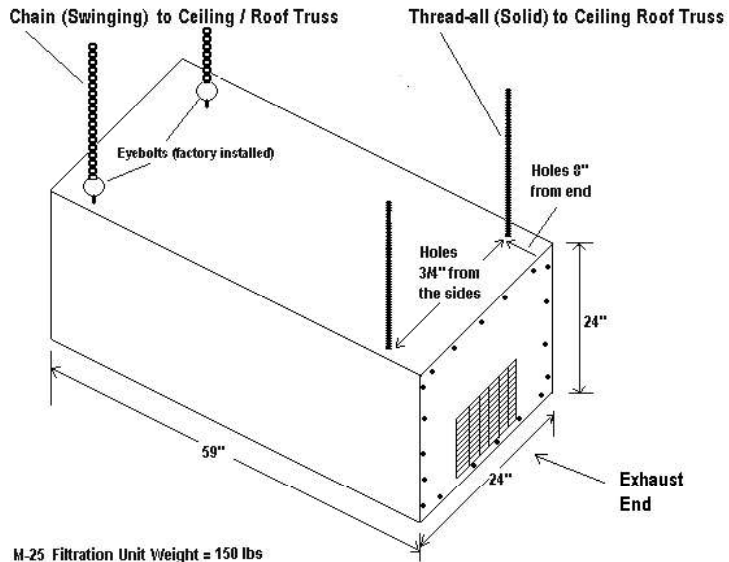

M-25 Filtration Unit Weight = 150 lbs

Electrical: 115VAC Single Phase with 12' power cord drawing 10.2 Amps

Option 2 - Wall Mounting Brackets

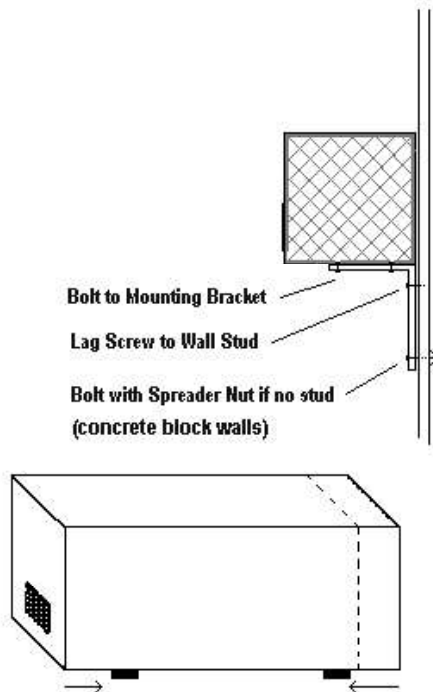

Brackets 6" end from ends ~
46-48" apart

All direct drive motors are protected with automatic restart overload protection.
All belt driven units must be protected externally.

OPERATION

Do not operate your units without filter for more than a few minutes at a time.

MAGNEHELIC PRESSURE GAGE OPTION

This is an option to help determine when to change the filters. As the bags fill with contaminants, the needle on the gage will rise. We recommend changing the bags between 1.25 – 1.50 above the reading with clean filters. It is normal to change the pleated twice (or more) as much as the inside bag filter. After the pleated has been change and there is no longer a drop in pressure, then it is time to change main filter. The reading may vary depending upon the contaminants. Please consult your Sales Engineer for further information.

FILTERS

All units are equipped with replaceable type media filters. In some cases, where contaminants being picked up are dry, it is possible to blow the prefilters and reuse them. Filters are available in a number of different degrees of efficiencies. The filters in your new BSE unit have been selected by your representative to best collect your contaminant.

Media type filters become more efficient as they load with contamination. However, as the filters load up, the air flow volume will decrease and eventually will reach a point where they must be replaced to restore the original air flow. Changing the filters in your new BSE air cleaner is easy. Old filters are simply pulled out of the entrance end of the unit and new filters are installed. No tools are required. Turning the unit on when installing new filters will help to pull them into place.

GENERAL NOTE: CLEANING AND INSPECTION OF CABINET

After the dirty components have been removed, inspect the cabinet interior. Remove foreign material, wipe interior, and clean all filter seating surfaces.

When installing new filters, the opening in the bag filter and the prefilter should be in a vertical position. Be sure the cloth part of the bag does not bunch up between the bag header and the angle iron filter stops on the cabinet. The prefilter should be installed with the wire mesh to the inside of the unit. Replacement filters can be supplied by your representative.

LOUVERS

Four-way louvers are provided on all units to permit you to direct the discharge air away from pilot lights on heaters and to help you obtain the best air flow pattern for maximum cleaning.

PARTS

ALWAYS USE **BSE** REPLACEMENTS FILTERS & PARTS TO MAINTAIN WARRANTY.

TO ORDER REPLACEMENTS PARTS:

BSE INC
2246 Palmer Drive, Suite 108
Schaumburg, IL 60173
866-360-5675
sales@purexinc.com

BSE Contact Info:
W. www.purexinc.com
T. 866.360.5675
E. sales@purexinc.com

A-2500 Wiring Diagram

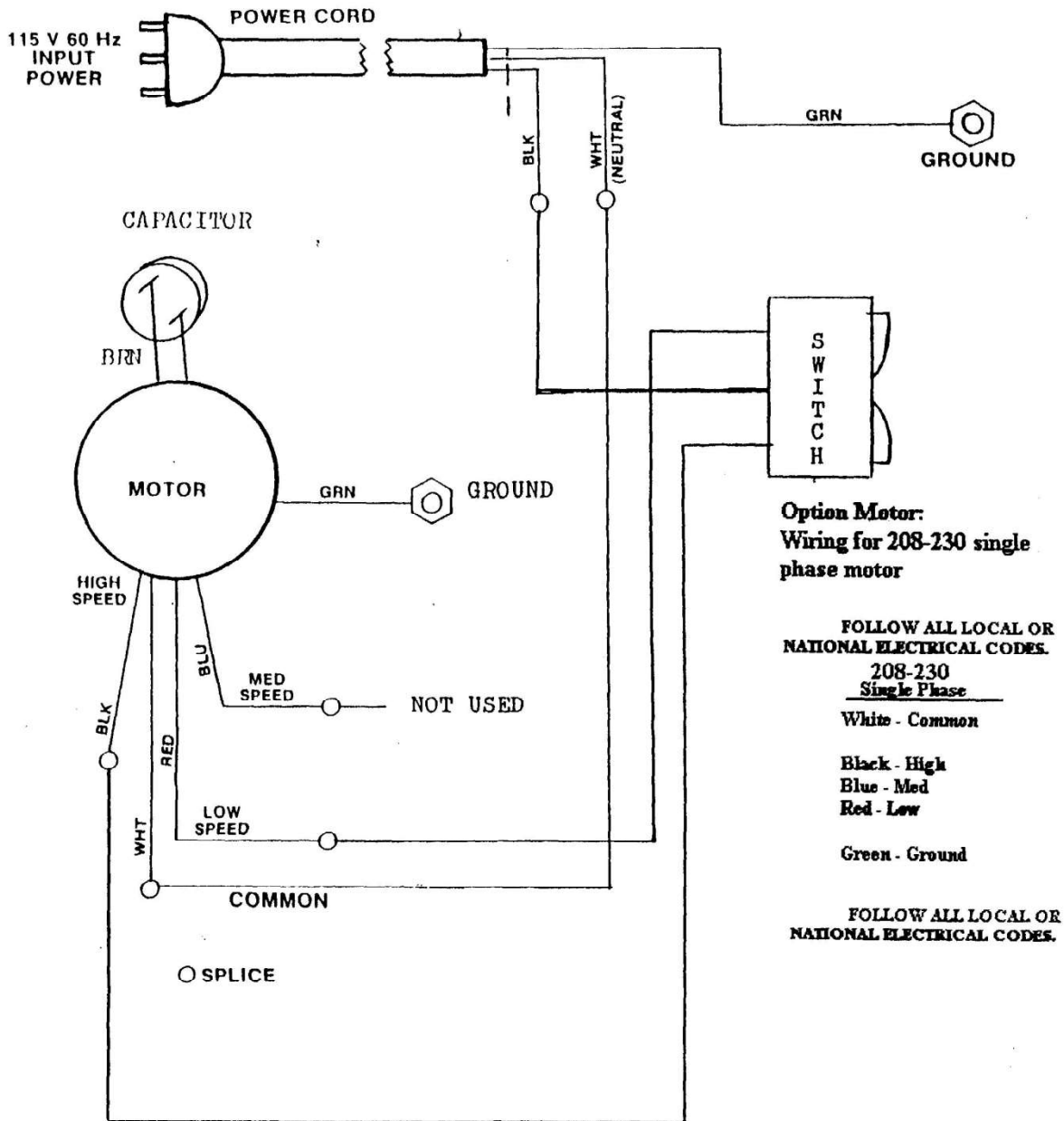

NOTE: For 277 voltage, wiring is the same as 208-230 single phase.

A-2500 with 3 speed Switch Wiring Diagram

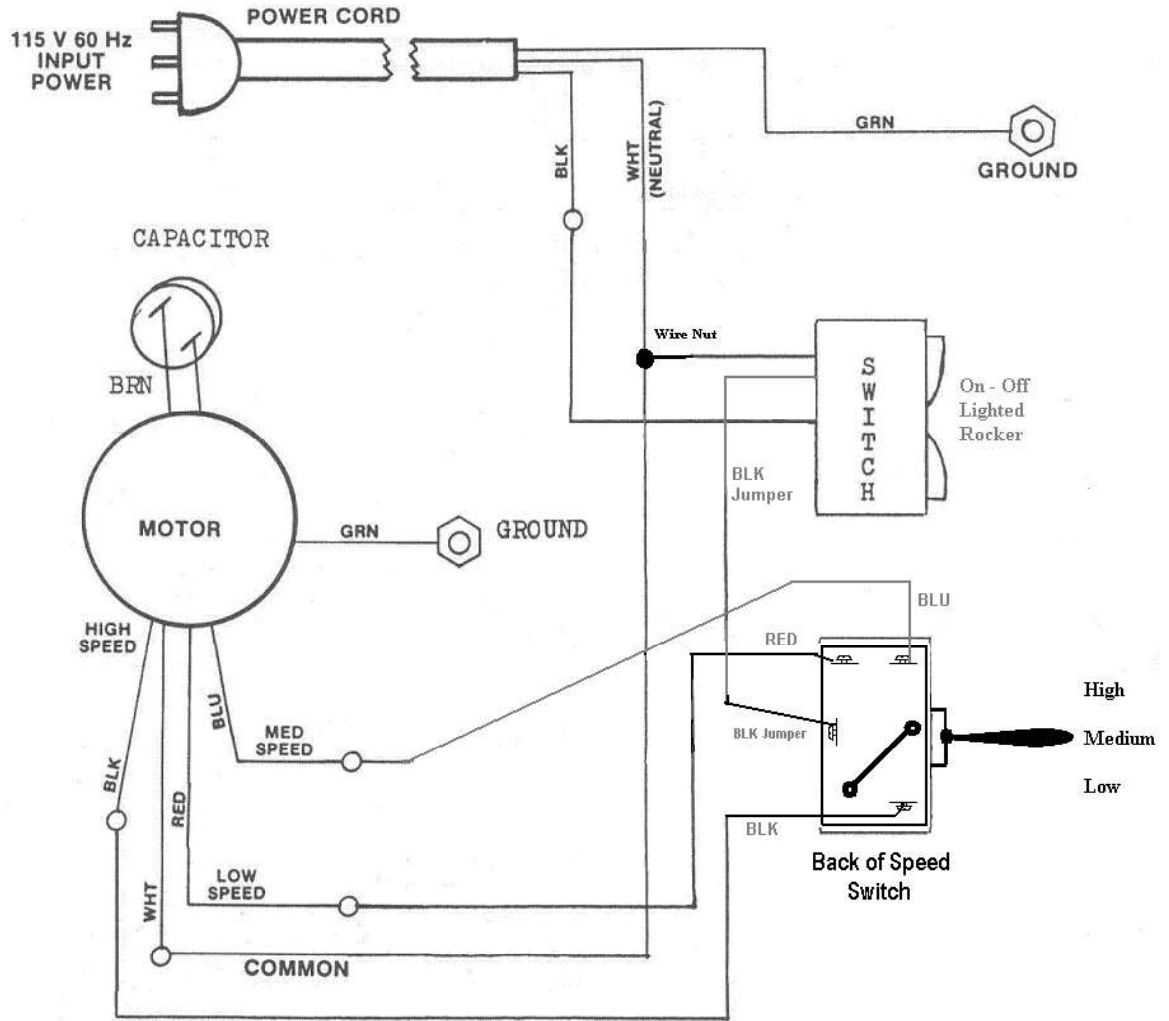

○ - SPLICE

BSE Contact Info:
W. www.purexinc.com
T. 866.360.5675
E. sales@purexinc.com

TROUBLE SHOOTING

Your **BSE** equipment has been manufactured to quality standards and tested for reliable operation at the factory. Proper operation and maintenance will result in excellent performance and longer service life.

PROBLEM	REMEDY
Motor starts with a whine and does not reach full speed.	If three phase powered, stop motor immediately . It may be "single phasing" and will overheat, possibly damaging internal windings. Check fuses and/or wires for an interruption in one of the lines. The motor may be operating on two phases only.
Motor makes a scraping or knocking noise.	Check motor cooling fan and its cover. It may have been damaged or shifted in transit and motor fan is rubbing. Check for loose blower wheel on motor shaft - tighten if necessary
No suction or pressure, or some suction but not as required (low or no airflow).	Check and open all dampers, if installed. Check ducting for blockage, if installed. Check for dirty or blocked, filters (refer to Maintenance section). Check rotation of fan.
Excess vibration.	Check structural support members. Tighten all bolts on legs and cross braces. Make sure entire structure is solid. Check for loose blower wheel - tighten if necessary.
Contaminants blowing through unit.	Check for torn or damaged filters. Check filter seals. If carbon module is used, make sure filter sock in place. Check door seals
Motor Over-amping nameplate	Access door open, close doors Incorrect Filters or no filters in the unit Ductwork faulty

If after performing the above TROUBLE SHOOTING the unit fails to perform to specifications, contact your **BSE** distributor for further assistance. In the unlikely event local help is unavailable, contact the factory for engineering assistance.

A-2500 MODEL

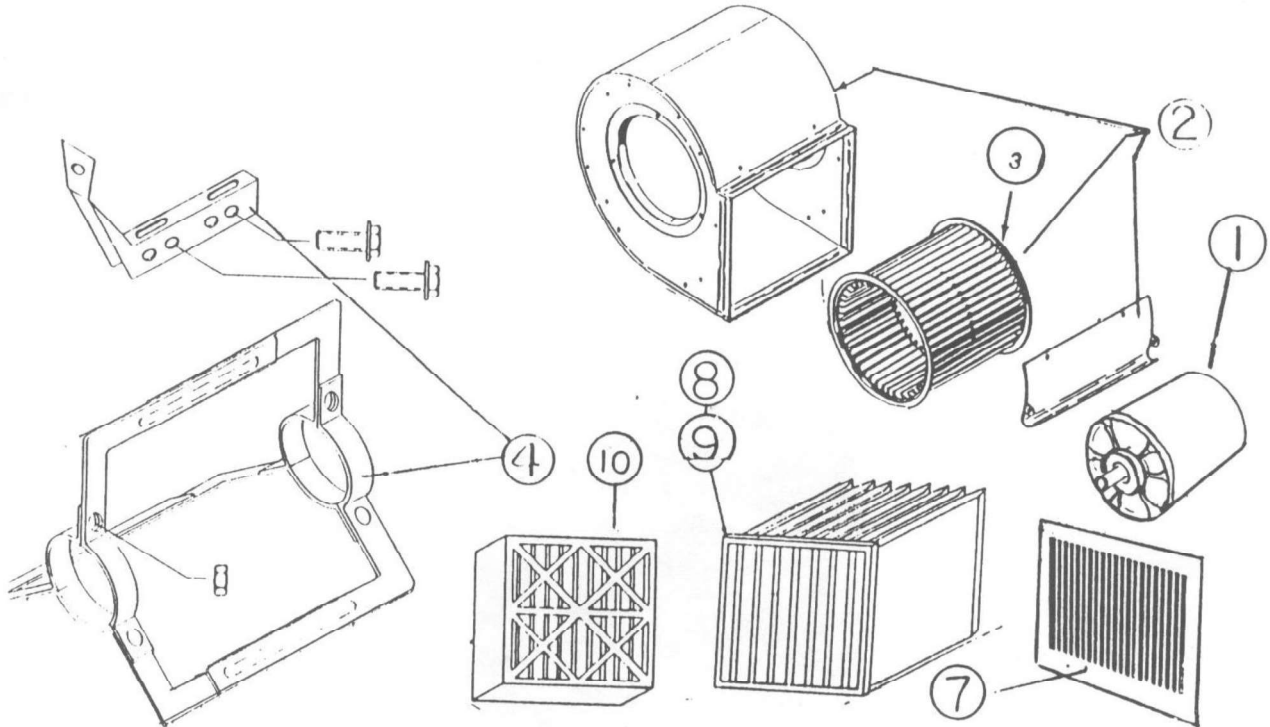

ITEM	PART #	DESCRIPTION
1	25-1000	3/4 H.P. DIRECT DRIVE
2	25-1500	10" COMPLETE BLOWER
3	25-1501	BLOWER WHEEL ONLY
4	25-1502	MOTOR MOUNT
5	25-2000	TWO SPEED SWITCH
6	25-2002	12" POWER CORD
7	25-3000	4 WAT ADJUSTABLE LOUVER
8	25-V95	95% 24X24X36" FILTER BAG
9	25-V65	65% 24X24X36" FILTER BAG
10	25-DP40	4" PLEATED PREFILTER
11	25-3507	4" ALUM MESH PREFILTER

MOTOR TROUBLE GUIDE

The purpose of this guide is to suggest common answers to electrical problems. The information is not all-inclusive and does not necessarily apply in all cases. When unusual operating conditions, repetitive failures, or other problems occur, consult an electric motor service firm for assistance.

TROUBLE	CAUSE - WHAT TO DO
MOTOR FAILS TO START	<p>Blown Fuses. - Replace with time-delay fuses or circuit breakers. Check for grounded winding.</p> <p>Low voltage. - Use higher voltage tap on transformer terminals, increase wire size. Check for poor connections.</p> <p>Improper line connections. - Check connections against diagram supplied with motor.</p> <p>Overload tripped. - Check and reset relay in starter. Check heater rating against motor nameplate current rating. Check motor load. If the motor has manual re-set thermal protector, check if it has been tripped.</p> <p>Motor may be overloaded. - Reduce load. Increase motor size.</p> <p>If permanent split capacitor motor, capacitor may be open. - Indicated by humming sound. Replace run capacitor. See nameplate for correct value.</p> <p style="text-align: center;">Defective motor or starter. - Repair or replace.</p>
MOTOR STALLS	<p style="text-align: center;">Overloaded motor. - Reduce load or increase motor size.</p> <p style="text-align: center;">Low motor voltage. - See that nameplate voltage is maintained.</p>
MOTOR DOES NOT COME UP TO SPEED	<p>Not applied properly. - Consult motor service firm for proper type. Use larger motor.</p> <p>Voltage too low at motor terminals due to line drop. - Use higher voltage tap on transformer terminals, increase wire size. Check for poor connections.</p> <p style="text-align: center;">Load too high. - Check load motor is carrying at start-replace with larger motor.</p>
MOTOR TAKES TOO LONG TO ACCELERATE	<p style="text-align: center;">Excess Loading; high inertia load. - Reduce load. Increase motor size.</p> <p>Inadequate wiring. - Increase wire size. Check for poor connections.</p> <p>Applied voltage too low. - Reconnect to a higher transformer tap. Increase wire size. Check for poor connections.</p> <p style="text-align: center;">Defective motor. - Repair or replace.</p> <p style="text-align: center;">Inadequate starting torque. - Replace with higher horsepower motor.</p>
MOTOR VIBRATES OR IS EXCESSIVELY NOISY	<p style="text-align: center;">Motor misaligned. - Realign.</p> <p style="text-align: center;">High voltages - Check wiring connections, transformer.</p> <p>Worn, damaged, dirty or overloaded bearings. - Replace, check loading and alignment.</p> <p style="text-align: center;">Loose or defective or out-of-balance air mover. - Tighten set screw(s), repair or replace.</p>
INSUFFICIENT SPEED CHANGE	<p>Insufficient motor load. - Use a lower horsepower motor. Reduce system restrictions (blower). Increase system restriction (blower fan).</p>
MOTOR OVERHEATS WHILE RUNNING UNDER LOAD	<p style="text-align: center;">Overload. - Reduce load; increase motor size.</p> <p style="text-align: center;">Dirt preventing ventilation. - Clean motor.</p> <p style="text-align: center;">Faulty connection. - Clean, tighten or replace.</p> <p>High or low voltage. - Check voltage at motor, should not be more than 10% above or below rated.</p> <p style="text-align: center;">Defective motor. - Repair or replace.</p>

BSE Contact Info:
W. www.purexinc.com
T. 866.360.5675
E. sales@purexinc.com